

TYPICAL CROSS SECTION OF CEMENT CONCRETE ROAD WITH CUTT OFF
(3.0M WIDE IN HARD SOIL AREA)

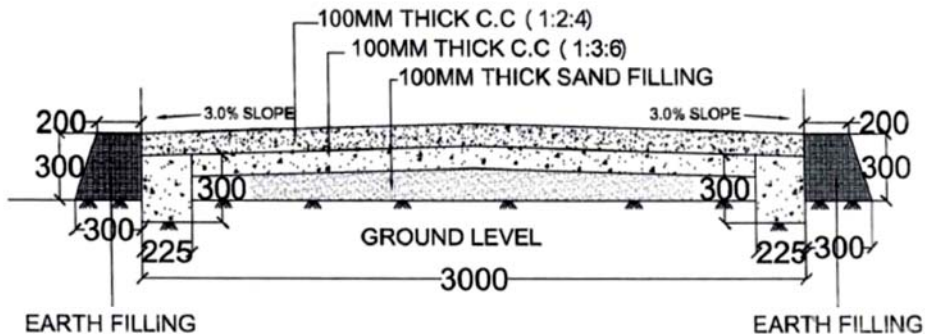

ALL DIMENSIONS ARE IN MM

ESTIMATED COST :-RS [REDACTED]